



## DH-P21 450 kg



# DH-P21 450 kg

## Application

The **DH-P21** is a **fully automatic linear lift**, suitable for mounting **inside the cargo space**, just in front of the rear doors of the vehicle. It can be mounted to a wide range of factory built panel vans and minibuses.

The construction with 2 lift arms provides **maximum platform stability** and increases the sense of safety of the operator.

The main lift controls consist of a handy 2-button remote control with spiral cable, allowing to operate all functions.

### Capacity chart

□ 250 kg	• DH-P11
□ 300 kg	• DH-VZ, C
■ 450 kg	• DH-P21
□ 500 kg	• DH-LSP, LC2, LSP4
□ 750 kg	• DH-LC, LSP4

## Characteristics & equipment

**CAPACITY** • 450 kg

**TYPE** • 2 lift arms for maximum stability  
• 2 single acting hydraulic lift cylinders

**PLATFORM** • Spacious platform with useful space of :

Width (mm)	Depth (mm)
820	1350 - 1150 - 1070
920 (option)	1350

- Other platform dimensions upon request
- Flat platform in aluminium with anti-slip surface
- Automatic roll-stop on the platform point [1]
- Automatic bridge plate to the loading floor, mounted to the floor plate of the lift [2]
- Mechanical lock for the platform in the driving / road position

**CONTROLS** • 2-button wander lead with spiral cable for the functions open / close / lift / lower  
• Controlled without electronic components

**POWER PACK** • Electro-hydraulic power pack premounted on the frame of the lift  
• 12 or 24V power pack  
• Fast manual emergency operation available for the lowering function  
• Battery switch premounted on the power pack

**LIFT HEIGHT** • Max. 900 mm above groundlevel

**PROPER WEIGHT** • From 140 kg onwards (depending on execution)

**AND FURTHER...** • Low maintenance bushes fitted to all articulation points  
• Intensive dampening of mechanical driving noises  
• Quick and easy mounting  
• Equipment conforms with CE safety Directives

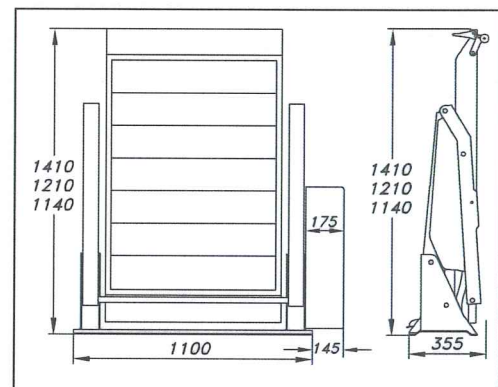



## ● Main Options (other options on request)



**S953** Vertically folding platform for clear and free passage through the doorway (model shown = DH-P20, DH-P21 is excl. safety gates)



**S957** Foldable platform for reduction in required fitting height, and for maximum driver's view through the rear vehicle doors (model shown = DH-P20, DH-P21 is excl. safety gates)



**S958** Non-standard platform width



**S955** Bridge plate mounted to platform (side gates = non standard)

## ● Examples of special mountings

