



→ Tail lift for factory built panel vans

## DH-LSP.07 • 500 - 750<sup>(\*)</sup> kg



The DH-LSP.07 types 02 and 03 are derived from the basic model DH-LSP.05. Types 02 and 03 **solve a number of mounting issues** for well-defined types of vans, that couldn't be solved elegantly with the standard model.

The **innovating shape of the lift arms** is specially designed for vans where the vertical distance between the loading floor of the vehicle and the under side of the doors is significantly above average, and eliminates the necessity to cut in the steel construction of the body.

The passage from the platform to the vehicle floor is realized by an articulated bridge plate, available as option on this lift (OAM008).

Most frequently, type 02 is mounted to Iveco Daily, Renault Master RWD and equivalent vehicles; type 03 is specially adapted to Ford Transit RWD.

### Lift capacity

CAP	CG	LM
500 kg	600 mm	3 kNm
750 kg (*)	600 mm	4.5 kNm

### Weights [see pg. 15]

ALU platform	
1300 mm	183 kg
1550 mm	190 kg

(\*) Depends on vehicle restrictions.  
Ask advice from DHOLLANDIA.

# Largest possible platform surface on factory built panel vans

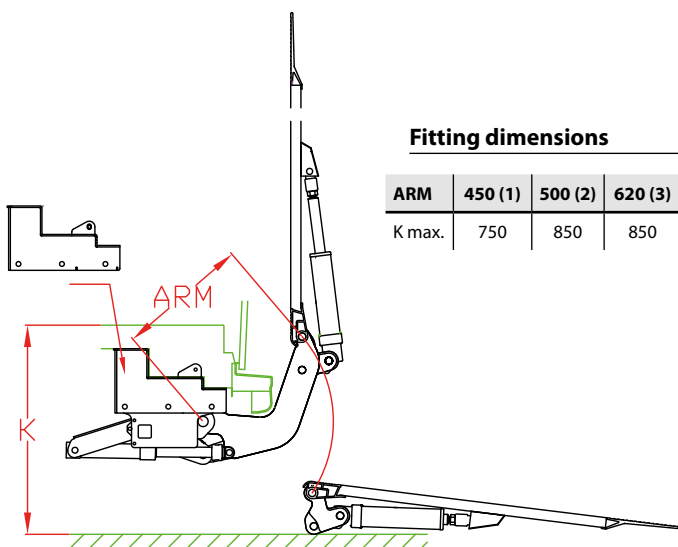

## Fitting dimensions

ARM	450 (1)	500 (2)	620 (3)
K max.	750	850	850

- (1) Renault Master RWD, Opel Movano RWD, Nissan NV400 RWD  
 (2) Iveco Daily  
 (3) Ford Transit RWD

## Technical specifications

Lift frame	Compact frame for max. ground clearance
Cylinders	2 lift cylinders + 1 tilt cylinder
Type of ride [see pg. 8-9]	Wedged platform. Level ride + automatic tilt at ground level
Platform material	Light-weight aluminium
Standard platform depths	Alu: 1300 - 1550 mm Longer platforms on request (OAP302.A)
Standard platform widths	Alu: 1450 mm Free up to 1550 in steps of 5 mm
Lift arm lengths	450 - 500 mm
Lift arm widths CA	240 (LSPZ half width) - 674 mm
Standard control unit [see pg. 11]	OAE031.Z
Standard finish of the lift frame	Protection PLUS [OAT102]

## Special mounting brackets are available for:

- Renault Master RWD (T2)
- Opel Movano RWD (T2)
- Iveco Daily (T2)
- Nissan NV400 RWD (T2)
- Ford Transit RWD (T3)